



EnergyMetering

Domestic water meters

Multi-jet wet dial meters

Multi-jet dry dial meters

Multi-jet semi-dry dial meters/Roller Protect

Cartridge meters



ZENNER
All that counts.

Domestic water meters

Multi-jet meters for cold and hot water

Our multi-jet turbine meters are designed for situations where a wide flow range must be covered. Quick responsiveness, even at low flow rates, combined with power reserves for high flow rates makes this meter model the ideal partner for service connections in water supply.

Constant development guarantees accurate measuring results and the best long-term stability. Constructional details, such as the design of the turbines result in excellent true running characteristics and minimum bearing loads. All movable parts have an optimised specified weight. Together with the special arrangement of the bearings and the turbine, this guarantees a minimal moment of friction and a long service life.

The body

Our bodies are constructed of a brass alloy in accordance with DIN 50 930 Part 6, manufactured in precision casting and processed highly precise on NC-controlled machines. They are all coated on the in and outside with a special epoxy resin. For metrological reasons the regulation takes place on the inlet side by regulating the bypass flow and the strainer is installed in the inlet in such a way as to prevent it from rotating. In contrast to a central strainer, this does not lead to measuring errors when pollution is uneven. The strainer can be replaced or cleaned easily and without damage to the calibration seal.

The tried and tested WVG-body is available or, on request, our flow-optimised ZR-body. Upstreaming or downstreaming pipe meter models (-ST/-F) are also available for vertical piping.



The measuring chamber

We use especially abrasion-proof and noncorrosive materials characterised by a low susceptibility to deposits. This allows us to achieve especially high operational reliability.

The turbine, supported at the centre of gravity, has a specific weight less than 1 g/cm^3 . The turbine thus, floats in the water and puts almost no pressure on the pinion. The unbalance is minimised by our own high precision injection moulding technology.

The inlet and outlet channels are arranged symmetrically and tangential. This prevents unilateral strain on the turbine support bearing in contrast to other design principles. The multitude of channels results in high measuring sensitivity and guarantees a wide measuring range; this is achieved in particular due to the stepped channels introduced by us. The measuring insert has a reduced diameter in the vicinity of the outlet channels. This optimises the flow characteristics and considerably reduces head loss.



The counter

The large counter rollers for the m^3 -display make reading the numbers much easier. Thanks to our standard 5-roller counter, a correct readout for consumption calculation is child's play. The four pointers even make it possible to read the decimal places, if need be. The star wheel shows the movement of the turbine, even at the lowest of flowrates and can, for example, be used to detect leakages.

In the case of conventional meters there is always the risk of the shaft sagging during longer periods of disuse. To prevent this, we use especially strong roller axles.

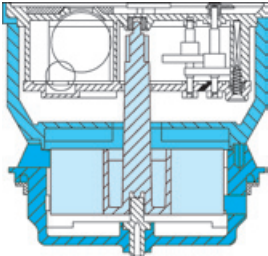

Cross-sectional drawing MNK

Construction wet dial

Our multi-jet turbine meters as wet dial model are characterised by the fact that the impeller shaft is connected directly with the counter. The counter's rollers and pointers are surrounded by the measuring fluid. The advantage here is that the power transmission from the measuring chamber takes place directly in the counter and thus, no friction losses occur. The result is a very low starting flow. In contrast to dry dial meters, this meter model cannot be influenced magnetically and metallic pollution cannot deposit itself on the impeller shaft or the coupling.

We recommend this meter for all potable water qualities where pollution of the counter through fine particles can be ruled out as far as possible.

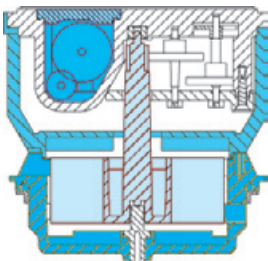

Cross-sectional drawing MNK-RP

Construction "Roller Protect"

With the model "Roller Protect" (-RP) we refer to a special type of counter which is a further development of the classic wet dial meter. Under conditions, over the years, fine deposits may set themselves on the counter rollers and the entire dial area of the MNK-meters, despite the encapsulated rollers in the counters. At worst, it becomes extremely difficult to read the meters.

This can be avoided with the hermetically encapsulated counter developed by us. The digit rollers are located in their own chamber, which is filled with a special protective fluid. No water and thus, no fine particles can enter the dial area. This way, the meter can be read even in polluted or highly ferrous water and thus, the meter is often referred to as a "semi-dry dial". Meters from the model MNK-RP are the ideal alternative in all situations where readings were often no longer possible.

We recommend this model for all potable water qualities where the danger of deposits due to rust or other fine particles exists or where the meter will remain in use much longer than the calibration period applicable in Germany.

Construction dry dial

With this meter, only the turbine functions in the wet chamber. The counter with the digit rollers is hermetically encapsulated and does not come into contact with the measuring fluid. Both parts of the measuring insert are connected by way of a state-of-the-art magnetic coupling. Malfunctions due to polluted water don't affect the encapsulated, evacuated and rotating counter.

We especially recommend cold water meters (MTK) for use in places where water quality varies. They can be used up to an operating temperature of 30 °C and are safe up to 50 °C. The hot water meters (MTW) can be used in calciferous water. The temperature limit for this model is 90 °C with a safety margin of up to 120 °C.

Option meters with pulse output

If a multi-jet meter with pulse output is required, then a model from the “-I-N”-range should be your first choice. They combine all of the advantages of a normal multi-jet meter with the possibility of remote meter readings. They allow you to connect them at any time to central metering systems, such as M-bus systems or radio modules.

The pulser is designed as a potential-free reed-switch and guarantees the highest compatibility with all conventional electronic modules available on the market today. Readout is impaired at no point in time. We also offer a pulser that can electronically detect interferences or malfunctions – even those intended. Naturally, the contact devices can be sealed and be replaced on location without damaging the calibration seal on the meter.

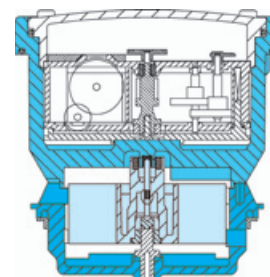

Cross-sectional drawing MNK





Option marking ring

The plastic marking ring is an innovation from us. It is attached to the meter on the inside of the head ring and sealed with a screw. Individual designs with for example, a customer logo, ownership number, bar code or emergency telephone number are possible with laser lettering. Readability has been considerably improved due to the optimum contrast (black/white). Oxidised meter numbers are now a thing of the past. The marking ring can also be attached just before installation.

Option lid ring

A further possibility for individual meter labelling is the lid ring. It offers all of the design possibilities of the marking ring, is however already fixed to the head ring ex works.

Option individual logo

On request we'll be happy to label the meter with a customer logo, either on the instrument dial or on the meter lid. This makes the meter unique, which means it can be easily and clearly identified by the user.



Installation positions

The best measuring results are achieved with multi-jet meters when they are installed horizontally. This means that the counter faces up. In this position, the counters bearings are best discharged. The reduced friction produces the lowest starting flows.

Upstreaming and downstreaming pipe bodies for vertical piping are special body forms. These allow the measuring insert to continue to function in a horizontal position despite the vertical piping. The bearings carry considerably less load – in comparison with the vertical mounting of standard meters – and thus, guarantee improved long-term stability in the measuring results.

Norms and regulations

All of the meters we manufacture comply with the installation and connecting dimensions from DIN ISO 4064 resp. DIN 19684 Part 3 and other national and international standards and regulations. The existing PTB approvals have a right of continuance for the next 10 years and guarantee our customers reliable measurement technology.

We are perfectly equipped for all of the up-and-coming developments in the European approval procedures. We already successfully implement the approval and procedure with regard to the declaration of conformity in compliance with the regulations of the MID.

Our responsibility

It goes without saying, that we not only conform to all of the applicable legal requirements to environmental and health compatibility, but also fulfill our own, much stricter guidelines. The safety of all of the materials used is tested regularly with regard to drinking water suitability. We only use tested and approved plastic from well-known manufacturers for our counters. Our meter casings are made of quality brass from approved alloys. All of the materials we use comply with the current regulations in the Drinking Water Ordinance from the Federal Ministry of Health.





MNK

Multi-jet wet dial meters for cold water

The MNK is the tried and tested meter for domestic service connections. Constant development guarantees accurate measuring results and the best long-term stability. Special constructional details result in excellent true running characteristics, a low bearing load and guarantee a long service life.

The MNK is available in the well-known WVG body or the flow-optimised ZR-body.

Performance characteristics in overview

- Wet dial counter construction
- Proven through worldwide use a million times over
- Viewing window made of high-quality mineral glass, UV-proof plastic on request
- For horizontal piping



MNK-I-N

Multi-jet wet dial meters for cold water with pulser

If a wet dial with pulse output is required, then the MNK-I-N is the best choice. It combines all of the product advantages of the normal MNK with the possibility of carrying out remote meter readouts. The connection to an automation system or to remote readout modules, such as for example radio systems, is possible at any time.

Performance characteristics in overview

- Version with pulse output (reed) for remote readout systems
- Standard resolution 100 l/Imp, optionally available 10 l/Imp
- Viewing window made of high-quality UV-proof plastic
- For horizontal piping

MNK-RP

Multi-jet wet dial meters for cold water with protected rollers

The digit rollers in the counter of the meters range MNK-RP are located in their own chamber, which is filled with a special protective fluid. No water and thus no fine particles, can enter the dial area either. This makes the meter readable even in highly polluted or ferrous water.

Available in the well-known WVG body or the flow-optimised ZR-body.

Performance characteristics in overview

- Specially protected digit rollers
- Viewing glass is made of UV-proof plastic or high-quality mineral glass
- For horizontal piping



MNK-I-N-RP

Multi-jet wet dial meters for cold water with protected rollers and pulser

This meter combines all of the advantages of the MNK-RP and additionally offers the possibility for remote readouts via the pulser. The connection to an automation system or to remote readout modules, such as for example radio systems, is possible at any time.

Performance characteristics in overview

- Version with pulse output (reed) for remote readout systems
- Pulse value 100 l/Imp
- Viewing window made of high-quality UV-proof plastic
- For horizontal piping



MTK



Multi-jet dry dial meter for cold water

The multi-jet dry dial meter has been tried and tested at measuring points where a wet dial cannot be used or is not desired. It is characterised by the guaranteed readability of the digit rollers combined with the reliable measuring principle of a multi-jet meter. Constant development guarantees accurate measuring results and the best long-term stability.

It is available in the well-known WVG body or the flow-optimised ZR-body.

Performance characteristics in overview

- Counter construction dry dial
- Proven through worldwide use a million times over
- Viewing window made of high-quality UV-proof plastic, mineral glass on request
- For horizontal piping



MTK-I-N

Multi-jet dry dial meter for cold water with pulser

The MTK-I-N is a dry dial equipped with a pulser ex works. It combines all of the product advantages of the normal MTK with the possibility of carrying out remote meter readouts. The connection to an automation system or to remote readout modules, such as for example radio systems, is possible at any time.

Performance characteristics in overview

- Version with pulse output (reed) for remote readout systems
- Standard resolution 100 l/Imp, optionally available 1000/10/1 l/Imp
- Viewing window made of high-quality UV-proof plastic
- For horizontal piping

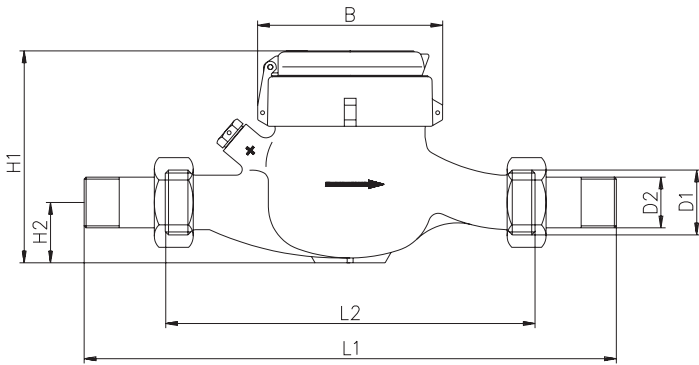

Dimensions MNK, MNK-RP, MTK

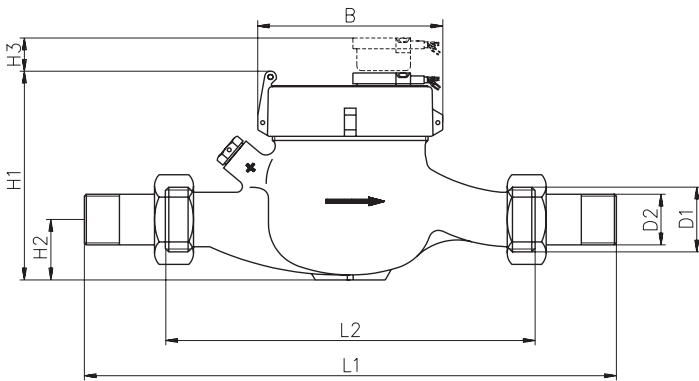

Dimensions MNK-I-N, MNK-I-N-RP

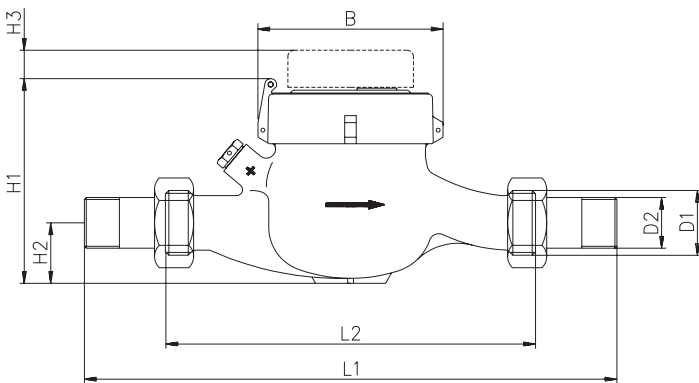

Dimensions MTK-I-N

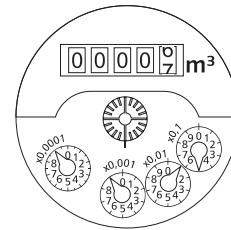

Dial MTK

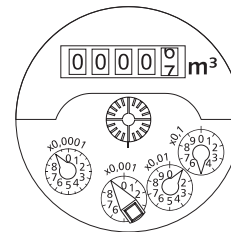

Dial MNK-I-N

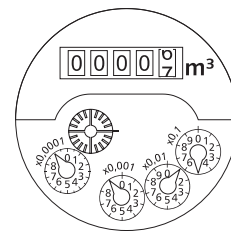

Dial MNK

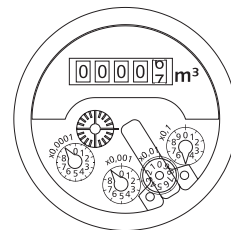

Dial MTK-I-N

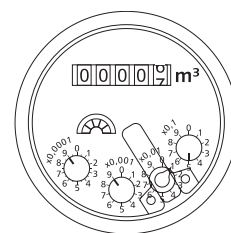

Dial MNK-RP

Technical data for the models MNK, MNK-I-N, MNK-PP, MNK-I-N-PP, MTK, MTK-I-N									
Nominal flow	Q _n	m ³ /h	1.5	1.5	1.5	1.5	2.5	2.5	2.5
Nominal diameter	DN	mm	15	15	15	25	20	25	20
		Inch	1/2	1/2	1/2	1	3/4	1	3/4
Overall length without conn.	L2	mm	110/115	165	170	175	220	175	190
Overall length with connectors	L1	mm	225/230	250	255	293	318	293	288
Thread meter G x B	D1	Inch	3/4	3/4	3/4	1 1/4	1	1 1/4	1
Thread connector R x	D2	Inch	1/2	1/2	1/2	1	3/4	1	3/4
Metrological class			C*H	C*H	C*H	C*H	C*H	C*H	C*H
			A*V	A*V	A*V	A*V	A*V	A*V	A*V
Maximum flow	Q _{max}	m ³ /h	3	3	3	3	5	5	5
Minimum flow	Q _{min}	l/h	15	15	15	15	25	25	25
Starting flow		l/h	4	4	4	4	5	5	5
Display range	min	l	0.05	0.05	0.05	0.05	0.05	0.05	0.05
	max	m ³	99,999	99,999	99,999	99,999	99,999	99,999	99,999
Maximum temperature		°C	30	30	30	30	30	30	30
Operating pressure, max.	PN	bar	16	16	16	16	16	16	16
Head loss at Q _{max}		bar	0.6	0.6	0.6	0.3	1	1	1
Pulse value		l/Imp	10/100	10/100	10/100	10/100	10/100	10/100	10/100
Height	H1 k*	mm	120	120	120	120	120	120	115
	H1 m*	mm	125	125	125	125	125	125	120
	H2	mm	35	35	45	40	40	40	32
	H3	mm	15	15	15	15	15	15	15
Width	B	mm	95	95	95	95	95	95	95
Weight		kg	1.4	1.4	1.7	1.7	1.9	1.8	1.8

k* plastic glass

m* mineral glass

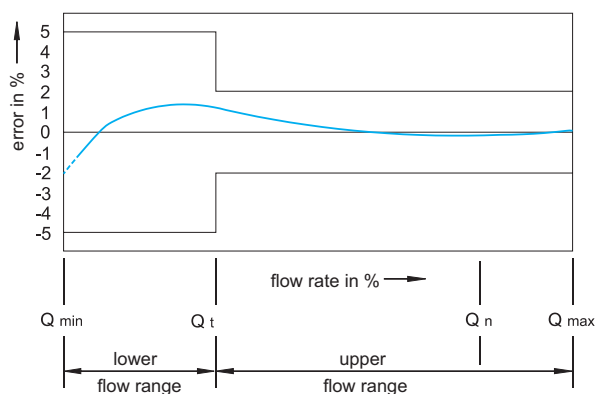

Typical accuracy curve

Technical data for the models MNK, MNK-I-N, MNK-PP, MNK-I-N-PP, MTK, MTK-I-N									
Nominal flow	Qn	m³/h	3.5	6	6	10	15	15	15
Nominal diameter	DN	mm	20	25	32	40	50	50	50
		Inch	1	1	1 1/4	1 1/2	2	-	-
Overall length without conn.	L2	mm	175	260	260	300	300	270	300
Overall length with connectors	L1	mm	293	378	378	438	438	-	-
Thread meter G x B	D1	Inch	1 1/4	1 1/4	1 1/2	2	2 1/2	Flange	Flange
Thread connector R x	D2	Inch	1	1	1 1/4	1 1/2	2	-	-
Metrological class			C*H	C*H	C*H	C*H	B*H	B*H	B*H
			A*V	A*V	A*V	A*V	A*V	A*V	A*V
Maximum flow	Qmax	m³/h	7	12	12	20	30	30	30
Minimum flow	Qmin	l/h	35	60	60	100	450	450	450
Starting flow		l/h	5	10	10	20	25	25	25
Display range	min	l	0.05	0.05	0.05	0.05	0.05	0.05	0.05
	max	m³	99,999	99,999	99,999	99,999	99,999	99,999	99,999
Maximum temperature		°C	30	30	30	30	30	30	30
Operating pressure, max.	PN	bar	16	16	16	16	16	16	16
Head loss at Qmax		bar	1	1	1	1	1	1	1
Pulse value		l/Imp	10/100	10/100	10/100	10/100	10/100	10/100	100
Height	H1 k*	mm	120	140	140	-	-	-	-
	H1 m*	mm	125	145	145	170	190	190	190
	H2	mm	40	50	50	60	75	75	75
	H3	mm	15	15	15	15	15	15	15
Width	B	mm	100	100	100	131	165	165	165
Weight		kg	1.8	2.7	2.7	5.4	5.4	12.4	12.4

k* plastic glass

m* mineral glass

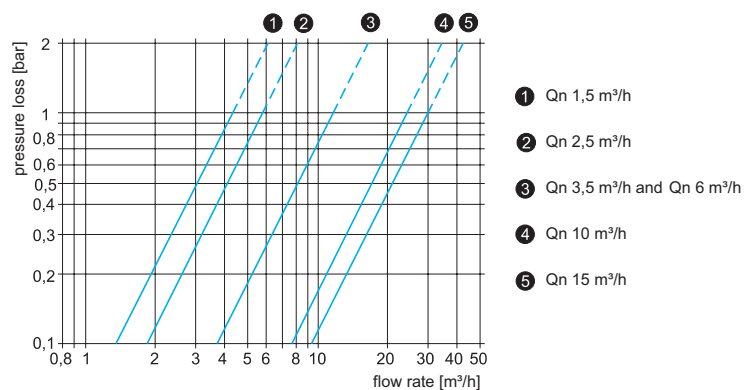

Head loss curves



MNK-ST

Multi-jet wet dial meter for cold water upstreaming pipe model

The tried and tested wet dial measuring insert in an upstreaming pipe body is available for installation in vertical piping with an ascending flow direction. This meter fits all installation points for upstreaming pipe meters and makes periodical replacement child's play.

In contrast to vertically mounted standard meters, the counter can continue to work in the horizontal position. The low bearing load connected with this results in the highly improved long-term stability of measuring results.

Performance characteristics in overview

- Viewing window made of high-quality mineral glass
- For vertical piping (upstreaming pipes)
- Horizontal counter position



MNK-I-N-ST

Multi-jet wet dial meter for cold water upstreaming pipe model with pulser

If a multi-jet wet dial with pulse output is required as an upstreaming pipe meter, then the MNK-I-N-ST is the best choice. It combines all of the product advantages of the normal MNK-ST with the possibility of carrying out remote meter readouts. The connection to an automation system or to remote readout modules, such as for example radio systems, is possible at any time.

Performance characteristics in overview

- Version with pulse output (reed) for remote readout systems
- Standard resolution 100 l/Imp, optionally available 10 l/Imp
- Viewing window made of high-quality UV-proof plastic
- For vertical piping (upstreaming pipes)

MTK-ST

Multi-jet dry dial meter for cold water upstreaming pipe model

The proven dry dial measuring insert in an upstreaming pipe body is available for installation in vertical piping with an ascending flow direction. This meter fits all installation points for upstreaming pipe meters and makes periodical replacement child's play.

In contrast to vertically mounted standard meters, the counter can continue to work in the horizontal position. The low bearing load connected with this results in the highly improved long-term stability of measuring results.

Performance characteristics in overview

- Viewing window made of high-quality UV-proof plastic
- For vertical piping (upstreaming pipes)
- Horizontal counter position



MTK-I-N-ST

Multi-jet dry dial meter for cold water upstreaming pipe model with pulser

The upstreaming pipe meter is also available with a pulser for remote readout systems.

Performance characteristics in overview

- Version with pulse output (reed) for remote readout systems
- Standard resolution 100 l/Imp, optionally available 1000/10 l/Imp
- Viewing window made of high-quality UV-proof plastic
- For vertical piping (upstreaming pipes)



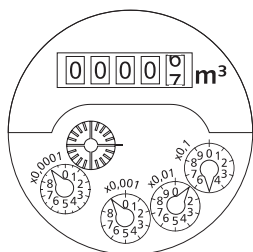

Dial MNK-ST

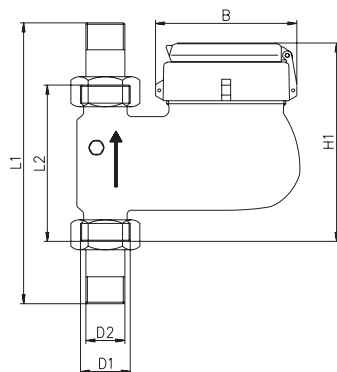

Dimensions MNK-ST

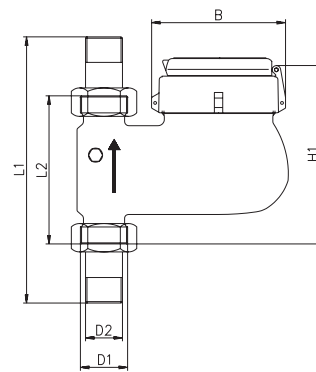

Dimensions MTK-ST

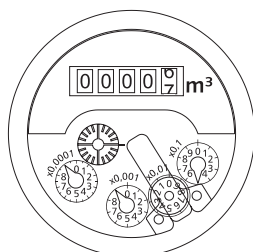

Dial MNK-I-N-ST

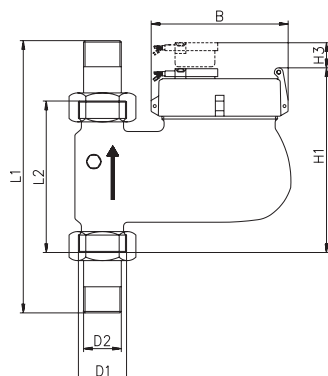

Dimensions MNK-I-N-ST

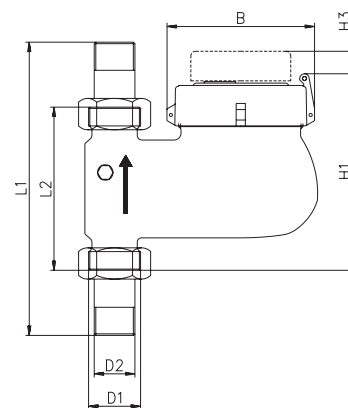

Dimensions MTK-I-N-ST

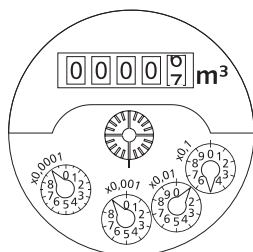

Dial MTK-ST

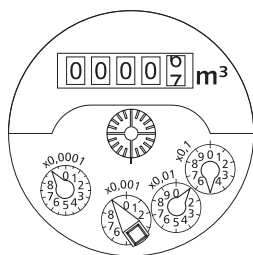

Dial MTK-I-N-ST

Technical data for the models MNK-ST, MNK-I-N-ST, MTK-ST, MTK-I-N-ST							
Nominal flow	Q _n	m ³ /h	2.5	3.5	6	10	10
Nominal diameter	DN	mm	20	25	25	40	40
		Inch	3/4	1	1	1 1/2	1 1/2
Overall length without connectors	L2	mm	105	150	150	150	200
Overall length with connectors	L1	mm	205	268	268	290	338
Thread meter G x B	D1	Inch	1	1 1/4	1 1/4	2	2
Thread connector R x	D2	Inch	3/4	1	1	1 1/2	1 1/2
Metrological class			B*H	B*H	B*H	B*H	B*H
Maximum flow	Q _{max}	m ³ /h	5	7	12	20	20
Minimum flow	Q _{min}	l/h	25	35	60	100	100
Starting flow		l/h	5	5	10	20	20
Display range	min	l	0.05	0.05	0.05	0.05	0.05
	max	m ³	99,999	99,999	99,999	99,999	99,999
Maximum temperature		°C	30	30	30	30	30
Operating pressure, max.	PN	bar	16	16	16	16	16
Head loss at Q _{max}		bar	1	1	1	1	1
Pulse value		l/Imp	10/100	10/100	10/100	10/100	10/100
Height	H1 k*	mm	136	161	161	161	168
	H1 m*	mm	141	166	166	166	173
	H3	mm	15	15	15	15	15
Width	B	mm	100	100	100	110	110
Weight		kg	1.9	3.2	3.2	5.2	6.3

k* plastic glass

m* mineral glass

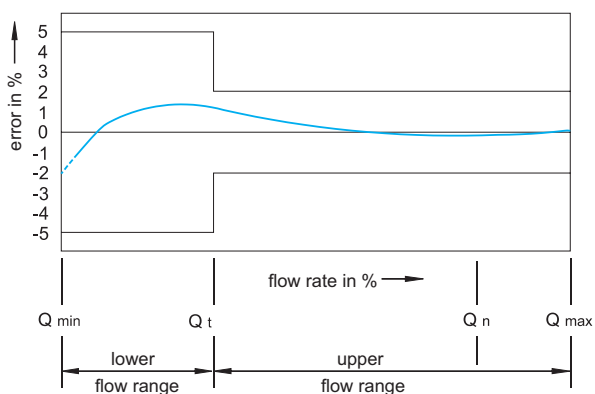

Typical accuracy curve

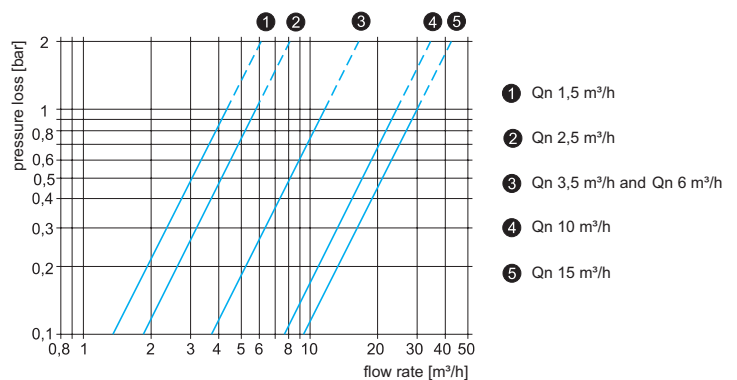

Head loss curves



MNK-F

Multi-jet wet dial meter for cold water downstreaming pipe model

The proven wet dial measuring insert in a downstreaming pipe body is available for installation in vertical piping with a descending flow direction. This meter fits installation points for downstreaming pipe meters and makes periodical replacement child's play.

In contrast to vertically mounted standard meters, the counter can continue to work in the horizontal position. The low bearing load connected with this, results in the highly improved long-term stability of measuring results.

Performance characteristics in overview

- Viewing window made of high-quality mineral glass
- For vertical piping (downstreaming pipes)
- Horizontal counter position



MNK-I-N-F

Multi-jet wet dial meter for cold water downstreaming pipe model with pulser

If a multi-jet downstreaming pipe meter with pulse output is required, then the MNK-I-N-F is the best choice. It combines all of the product advantages of the normal MNK-F with the possibility of carrying out remote meter readouts. The connection to an automation system or to remote readout modules, such as for example radio systems, is possible at any time.

Performance characteristics in overview

- Version with pulse output (reed) for remote readout systems
- Standard resolution 100 l/Imp, optionally available 10 l/Imp
- Viewing window made of high-quality UV-proof plastic
- For vertical piping (downstreaming pipes)

MTK-F

Multi-jet dry dial meter for cold water downstreaming pipe model

The tried and tested dry dial measuring insert in a downstreaming pipe body is available for installation in vertical piping with a descending flow direction. This meter fits all installation points for downstreaming pipe meters and makes calibration replacement child's play.

In contrast to vertically mounted standard meters, the counter can continue to work in the horizontal position. The low bearing load connected with this, results in the highly improved long-term stability of measuring results.

Performance characteristics in overview

- Viewing window made of high-quality UV-proof plastic
- For vertical piping (downstreaming pipes)
- Horizontal counter position



MTK-I-N-F

Multi-jet dry dial meter for cold water downstreaming pipe model with pulser

The downstreaming pipe meter is also available with a pulser for remote readout systems.

Performance characteristics in overview

- Version with pulse output (reed) for remote readout systems
- Standard resolution 100 l/Imp, optionally available 1000/10 l/Imp
- Viewing window made of high-quality UV-proof plastic
- For vertical piping (downstreaming pipes)



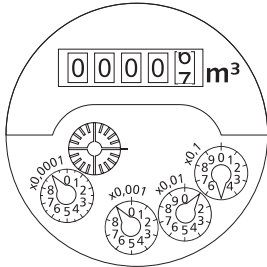

Dial MNK-ST

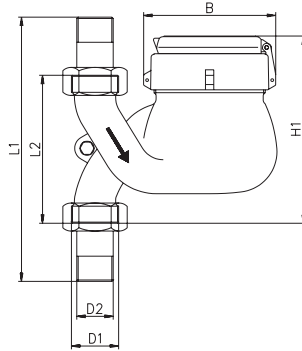

Dimensions MNK-F

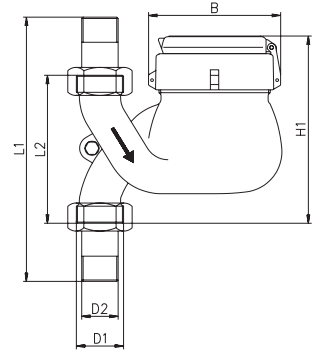

Dimensions MTK-F

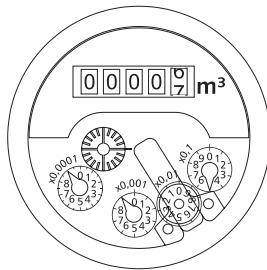

Dial MNK-I-N-ST

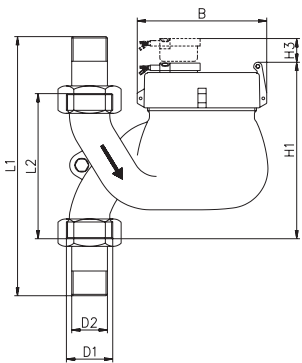

Dimensions MNK-I-N-F

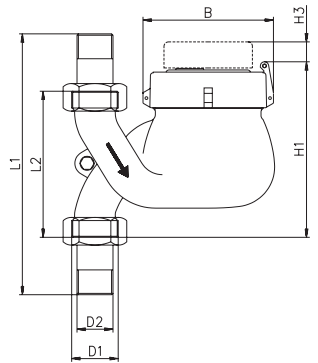

Dimensions MTK-I-N-F

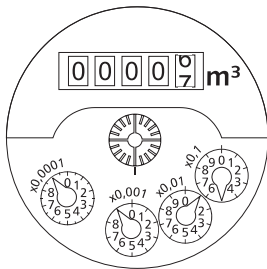

Dial MTK-ST

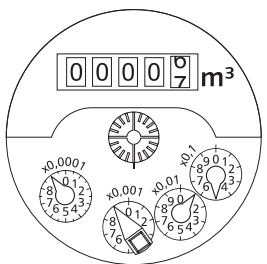

Dial MTK-I-N-ST

Technical data for the models MNK-F, MNK-I-N-F, MTK-F, MTK-I-N-F						
Nominal flow	Q _n	m ³ /h	2.5	2.5	6	10
Nominal diameter	DN	mm	20	20	25	40
		Inch	3/4	3/4	1	1 1/2
Overall length without conn.	L2	mm	105	190	260	300
	L2*	mm	105	-	150	-
Overall length with connectors	L1	mm	205	288	378	438
Thread meter G x B	D1	Inch	1	1	1 1/4	2
Thread connector R x	D2	Inch	3/4	3/4	1	1 1/2
Metrological class			B*H	B*H	B*H	B*H
Maximum flow	Q _{max}	m ³ /h	5	5	12	20
Minimum flow	Q _{min}	l/h	25	25	60	100
Starting flow		l/h	5	5	10	20
Display range	min	l	0.05	0.05	0.05	0.05
	max	m ³	99,999	99,999	99,999	99,999
Maximum temperature		°C	30	30	30	30
Operating pressure, max.	PN	bar	16	16	16	16
Head loss at Q _{max}		bar	1	1	1	1
Pulse value		l/Imp	10/100	10/100	10/100	10/100
Height	H1 k*	mm	136	161	174	196
	H1 m*	mm	141	166	179	101
	H3	mm	15	15	15	15
Width	B	mm	100	100	100	110
Weight		kg	1.6	1.8	2.8	5.4

* only dry dials

k* plastic glass

m* mineral glass

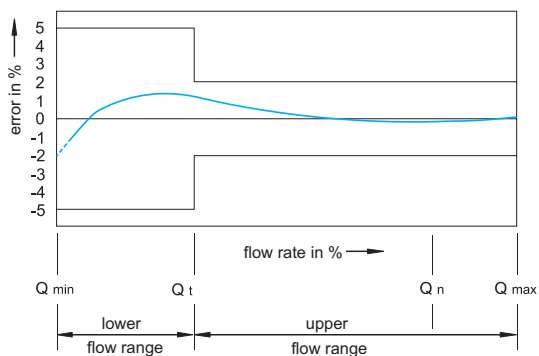

Typical gradient

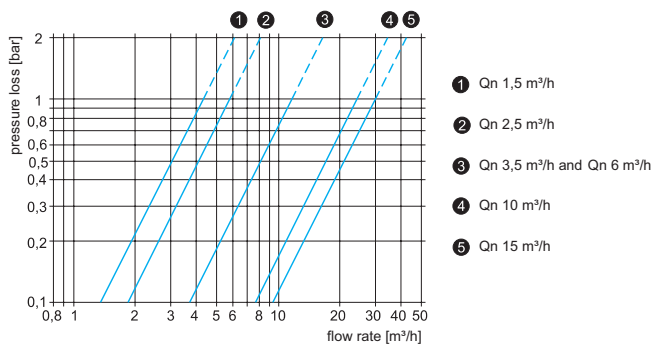

Head loss curves

MTW

Multi-jet dry dial meters for hot water

The hot water version of the multi-jet dry dial is ideal for measuring tasks at temperatures of up to 90 °C. Through the use of special materials we were able to combine the excellent measuring values with a higher temperature limit.

It is available in the well-known WVG body or the flow-optimised ZR-body.

Performance characteristics in overview

- Viewing window made of high-quality UV-proof plastic
- Hermetically sealed roller capsule
- For horizontal piping
- Also available in Class C

MTW-I

Multi-jet dry dial meters for hot water with pulser

This meter combines all of the advantages of the MTW and additionally offers the possibility for remote readouts with a pulser. The connection to an automation system or to remote readout modules, such as for example radio systems, is possible at any time.

Performance characteristics in overview

- Viewing window made of high-quality UV-proof plastic
- Version with pulse output (reed) for remote readout systems
- Pulse value 100 l/Imp
- For horizontal piping



Technical data for the models MTW, MTW-I						
Nominal flow	Qn	m ³ /h	2.5	6	6	10
Nominal diameter	DN	mm	20	25	30	40
		Inch	3/4	1	1 1/4	1 1/2
Overall length without conn.	L2	mm	190	260	260	300
Overall length with connectors	L1	mm	288	378	378	438
Thread meter G x B	D1	Inch	1	1 1/4	1 1/2	2
Thread connector R x	D2	Inch	3/4	1	1 1/4	1 1/2
Metrological class		B*H	B*H	B*H	B*H	B*H
		A*V	A*V	A*V	A*V	A*V
Maximum flow	Qmax	m ³ /h	5	12	12	20
Minimum flow	Qmin	l/h	50	120	120	200
Starting flow		l/h	10	18	18	25
Display range	min	l	0.05	0.05	0.05	0.05
	max	m ³	99,999	99,999	99,999	99,999
Maximum temperature		°C	90	90	90	90
Operating pressure, max.	PN	bar	16	16	16	16
Head loss at Qmax		bar	1	1	1	1
Pulse value		l/Imp	100	100	100	100
Height	H1 k*	mm	115	140	140	168
	H1 m*	mm	120	145	145	170
	H2	mm	32	50	50	60
Width	B	mm	95	100	100	131
Weight		kg	1.8	2.7	2.7	5.4

k* plastic glass

m* mineral glass

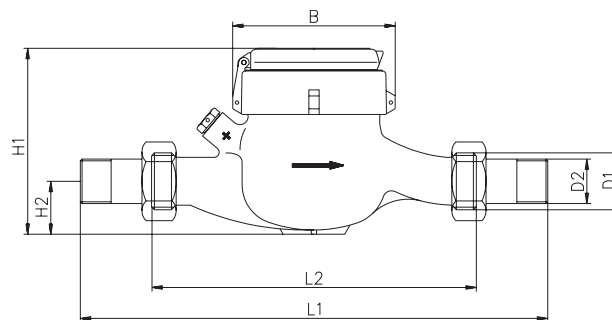

Dimensions MTW



MTW-ST

Multi-jet dry dial meter for hot water upstreaming pipe model

The proven multi-jet measuring insert in an upstreaming pipe body is available for installation in vertical piping with an ascending flow direction. This meter fits all installation points for upstreaming pipe meters and makes periodical replacement child's play.

In contrast to vertically mounted standard meters, the counter can continue to work in the horizontal position. The low bearing load connected with this, results in the highly improved long-term stability of measuring results.

Performance characteristics in overview

- Viewing window made of high-quality UV-proof plastic
- For vertical piping (upstreaming pipes)
- Horizontal counter position



MTW-I-ST

Multi-jet dry dial model for warm water upstreaming pipe model with pulser

If a multi-jet upstreaming pipe meter with pulse output is required, then the MTW-I-ST is the best choice. It combines all of the product advantages of the normal MTW-ST with the possibility of carrying out remote meter readouts. The connection to an automation system or to remote readout modules, such as for example radio systems, is possible at any time.

Performance characteristics in overview

- Version with pulse output for remote readout systems
- Standard resolution 100 l/Imp, optionally available 10 l/Imp
- Viewing window made of high-quality UV-proof plastic
- For vertical piping (upstreaming pipes)

Technical data for the models MTW-ST, MTW-I-ST					
Nominal flow	Qn	m³/h	2.5	6	10
Nominal diameter	DN	mm	20	25	40
		Inch	3/4	1	1 1/2
Overall length without conn.	L2	mm	105	150	150
Overall length with connectors	L1	mm	205	268	268
Thread meter G x B	D1	Inch	1	1 1/4	2
Thread connector R x	D2	Inch	3/4	1	1 1/2
Metrological class			B*H	B*H	B*H
Maximum flow	Qmax	m³/h	5	12	20
Minimum flow	Qmin	l/h	50	120	200
Starting flow		l/h	10	18	25
Display range	min	l	0.05	0.05	0.05
	max	m³	99,999	99,999	99,999
Maximum temperature		°C	90	90	90
Operating pressure, max.	PN	bar	16	16	16
Head loss at Qmax		bar	1	1	1
Pulse value		l/Imp	100	100	100
Height	H1 k*	mm	136	161	168
	H1 m*	mm	141	166	173
	H3	mm	15	15	15
Width	B	mm	100	100	100
Weight		kg	2.0	3.0	5.0

k* plastic glass

m* mineral glass

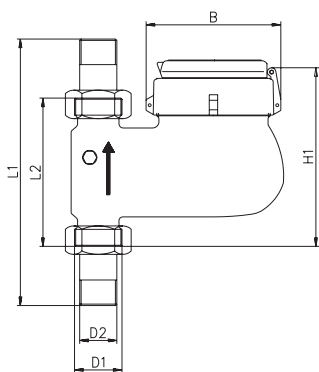

Dimensions MTW-ST

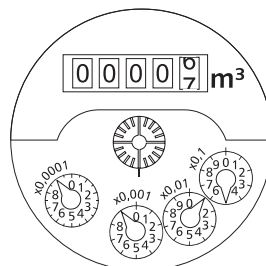

Dial MTW-ST



MTW-F

Multi-jet dry dial meter for hot water downstreaming pipe model

The proven multi-jet measuring insert in a downstreaming pipe body is available for installation in vertical piping with a descending flow direction. This meter fits all installation points for downstreaming pipe meters and makes calibration replacement child's play.

Performance characteristics in overview

- Viewing window made of high-quality UV-proof plastic
- For vertical piping (downstreaming pipes)
- Horizontal counter position

Technical data for the model MTW-F

Nominal flow	Qn	m ³ /h	2.5	6	10
Nominal diameter	DN	mm	20	25	25
		Inch	3/4	1	1 1/2
Overall length without conn.	L2	mm	105	150	150
Overall length with connectors	L1	mm	205	268	268
Thread meter G x B	D1	Inch	1	1 1/4	2B
Thread connector R x	D2	Inch	3/4	1	1 1/2
Metrological class			B*H	B*H	B*H
Maximum flow	Qmax	m ³ /h	5	12	20
Minimum flow	Qmin	l/h	50	120	200
Starting flow		l/h	10	18	25
Display range	min	l	0.05	0.05	0.05
	max	m ³	99,999	99,999	99,999
Maximum temperature		°C	90	90	90
Operating pressure, max.	PN	bar	16	16	16
Head loss at Qmax		bar	1	1	1
Pulse value		l/Imp	-	-	-
Height	H1 k*	mm	136	174	196
	H1 m*	mm	141	179	101
Width	B	mm	100	100	100
Weight		kg	2.0	3.0	5.0

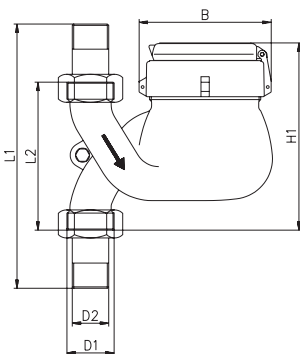

Dimensions MTW-F

k* plastic glass m* mineral glass

Mobile radio system

Remote readout system for domestic water meters

We have developed a mobile radio system especially for the remote readout of domestic water meters. It works with bi-directional data transmission, i.e. the device is sender and receiver at the same time.

The radio modules are addressed individually and the data is received with a mobile hand-held computer. Consumption data and meter parameters are then read on the PC in the office and transferred to the billing system. The mobile radio system is also suited for readouts in hard-to-reach places, such as meter pits. While at least two service workers are usually needed to open, secure and enter a pit, with the mobile radio system only one employee is needed to read the data from a comfortable distance. The optimises processes and saves valuable resources.

Performance characteristics in overview

- No need for setting up dates between the readout personnel and the caretaker
- Tenant privacy is not disrupted
- Readout with a hand-held computer
- Compact device or split-module for meters with pulse output



Technical data radio system

Device description	Compact device / split-module
Frequency	433 / 868 MHz
Transmission method	Bi-directional
Readout	Walk-by (PDA)



PATROL-MNK

Multi-jet wet dial cartridge meter for cold water

The multi-jet turbine meter PATROL is based on the tried and tested wet dial measuring insert. It was, however, designed with a replaceable and certified measuring cartridge. After calibration validity has expired, the body remains in the pipe network and only the measuring cartridge is replaced. The periodical replacement is thus, inexpensive and as easy as child's play.

Performance characteristics in overview

- Viewing window made of high-quality UV-proof plastic
- For horizontal piping
- Simple handling – inexpensive meter replacement
- The cartridge can be rotated and is always readable
- On request with a backflow preventer in the body
- Almost noiseless
- Version available with pulser



PATROL-MNK-ST

Multi-jet wet dial cartridge meter for cold water upstreaming pipe model

The proven multi-jet cartridge in an upstreaming pipe body is available for installation in vertical piping with an ascending flow direction. This meter fits all installation points for upstreaming pipe meters and makes periodical replacement child's play.

Performance characteristics in overview

- Viewing window made of high-quality UV-proof plastic
- For vertical piping (upstreaming pipes)
- Horizontal counter position
- Version available with pulser

PATROL-RTK

Positive displacement dry dial cartridge meter for cold water

A measuring cartridge with the positive displacement measuring principle is also available for the well-known PATROL-body. It's advantage is that it has very low starting values and can be mounted in any installation position.

Performance characteristics in overview

- Viewing window made of high-quality UV-proof plastic
- Extremely low starting value
- Encapsulated counter can be rotated by 350°
- Accuracy class C
- Any installation position possible
- Version available with pulser



PATROL-RTK-ST

Positive displacement dry dial cartridge meter for cold water upstreaming pipe model

Although positive displacement meters can be installed horizontally and vertically, we recommend using the appropriate body for upstreaming pipes. Thus, the measuring point remains compatible with the conventional body forms and the meter can continue to function in the optimum counter position.

Performance characteristics in overview

- Viewing window made of high-quality UV-proof plastic
- For vertical piping (upstreaming pipes)
- Horizontal counter position
- Accuracy class C



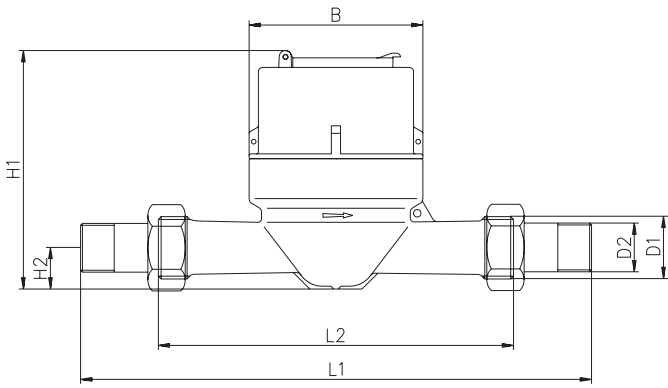

Dimensions Patrol-MNK

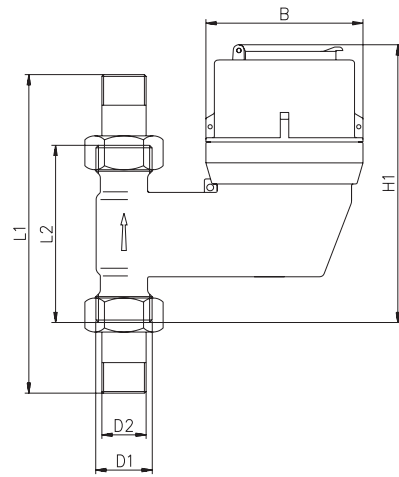

Dimensions Patrol-MNK-ST

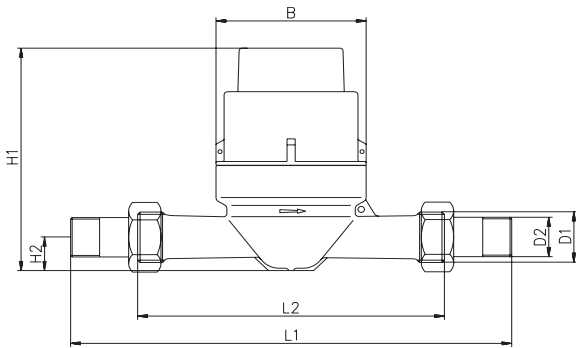

Dimensions Patrol-RTK

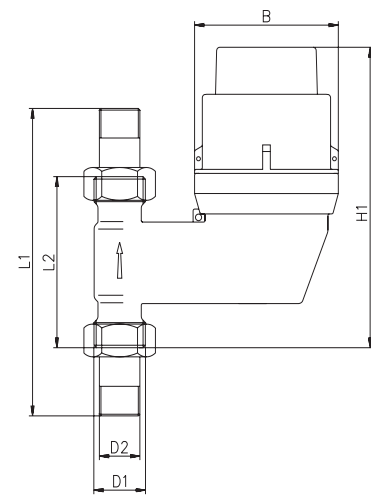

Dimensions Patrol-RTK-ST

Technical data for the models MNK-P, MNK-P-ST, RTK-P, RTK-P-ST			MNK-P	MNK-P-ST	RTK-P	RTK-P-ST
Nominal flow	Qn	m ³ /h	2.5	2.5	2.5	2.5
Nominal diameter	DN	mm	20	20	20	20
		Inch	3/4	3/4	3/4	3/4
Overall length without conn.	L2	mm	190	105	190	105
Overall length with connectors	L1	mm	288	205	288	205
Thread meter G x B	D1	Inch	1	1	1	1
Thread connector R x	D2	Inch	3/4	3/4	3/4	3/4
Metrological class			B*H	B*H	C	C*H
Maximum flow	Qmax	m ³ /h	5	5	5	5
Minimum flow	Qmin	l/h	25	25	25	25
Starting flow		l/h	5	5	2	2
Display range	min	l	0.05	0.05	0.05	0.05
	max	m ³	99,999	99,999	99,999	99,999
Maximum temperature		°C	30	30	30	30
Operating pressure, max.	PN	bar	16	16	16	16
Head loss at Qmax		bar	0.8	0.9	1	1
Pulse value		l/Imp	-	-	1	1
Height	H1	mm	130	135	140	140
	H2	mm	22	-	22	-
Width	B	mm	93	95	93	93
Weight		kg	1.6	2.0	1.7	1.7

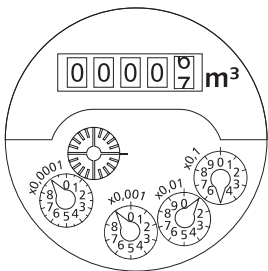

Dial MNK-P, MNK-P-ST

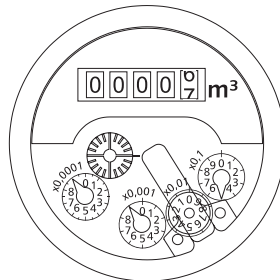

Dial MNK-P-I-N

ZENNER International GmbH & Co. KG

Römerstadt 4
D-66121 Saarbrücken, Germany

Telephone +49 6 81 99 676-0
Fax +49 6 81 99 676-100

E-Mail info@zenner.com
Internet www.zenner.com